

Trójniki V

Model 1

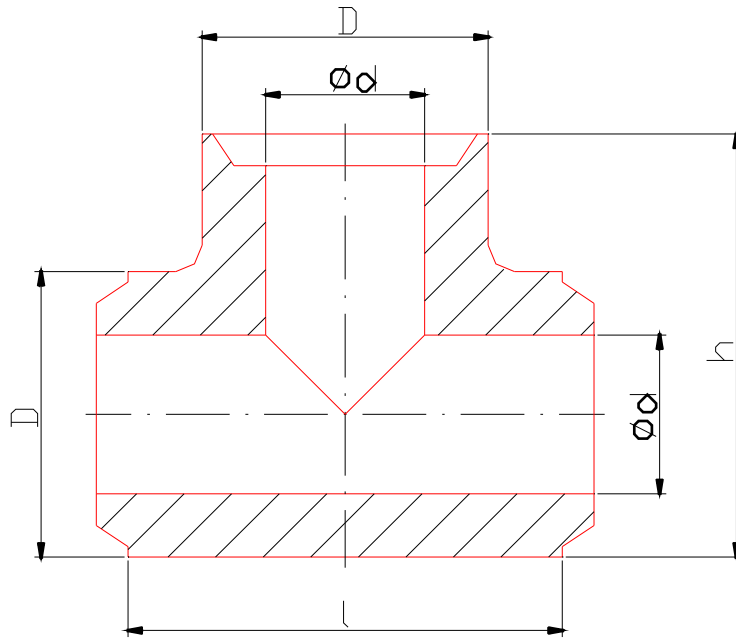

Model 2

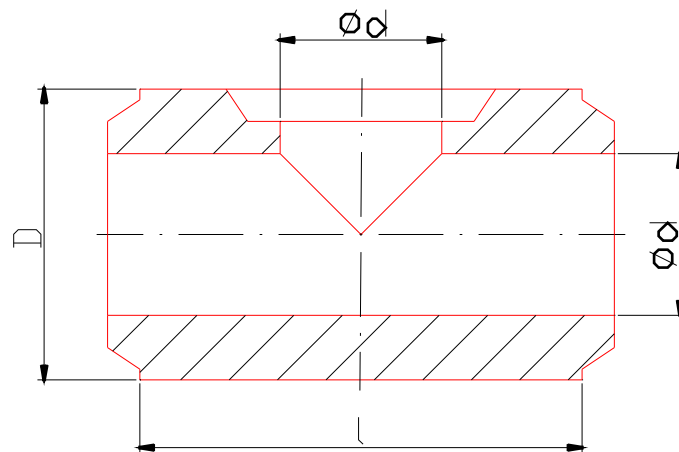

Symbol	Model	Rozmiar				Waga kg	szt./pal.
		d	D	h	l		
V 30-30-30	1	30	54	80	82	0,4	1260
V 30-30-30	2	30	64	-	100	0,8	1260
V 40-40-40	1	40	64	90	100	0,8	960
V 40-40-40	2	40	74	-	115	0,9	960
V 50-50-50	1	50	74	105	110	1,0	660
V 50-50-50	2	50	94	-	145	2,0	660
V 60-60-60	1	60	94	132	135	1,3	480
V 60-60-60	2	60	94	-	145	1,0	480
V 70-70-70	1	70	110	145	145	2,6	280
V 80-80-80	2	80	120	-	120	2,1	270
V 100-100-100	2	100	140x150 szerokość x wysokość	-	140	2,9	195